

**Modular Cooking Range Line
 thermaline 80 - 500 mm Freestanding
 Electric Free-cooking Top, Smooth Plate,
 1 Side, H=700**

ITEM # _____

MODEL # _____

NAME # _____

SIS # _____

AIA # _____



588378 (MATDEAEDAO) Electric Free-Cooking Top,
 one-side operated

Short Form Specification

Item No. _____

Unit constructed according to DIN 18860_2 with 20 mm drop nose top and 70 mm recessed plinth. Internal frame for heavy duty sturdiness in stainless steel. 2 mm top in 1.4301 (AISI 304). Flat surface construction, easily cleanable. THERMODUL connection system enables seamless worktop when units are connected and avoids soil penetrating. Smooth electrically-heated solid plate made of 20 mm thick steel with a wide rounded cleaning zone around the plate. Rapid plate heat up, continuously ready to use; maximum reachable surface temperature of 350°C. Overheat protection switches off the supply in case of overheating. Standby function saves energy and quickly recovers maximum power. Metal knobs with embedded hygienic silicon "soft" grip enable easier handling and cleaning.
 IPX5 water resistance certification.
 Configuration: Freestanding, one-side operated.

Main Features

- For direct and indirect cooking.
- Rapid heat up of the plate and continuously ready for use.
- Overheat protection: the temperature sensor switches off the supply in case of overheating.
- Wide rounded cleaning zone around the plates for easier cleaning.
- All major components may be easily accessed from the front.
- THERMODUL connection system creates a seamless work top when units are connected to each other thus avoiding soil penetrating vital components and facilitating the removal of units in case of replacement or service.
- Metal knobs with embedded hygienic "soft-touch" grip for easier handling and cleaning. The special design of the controls prevents infiltration of liquids or soil into vital components.
- Large visible digital display manufactured in tempered glass to resist heat and chemicals, showing temperatures or power settings. The display also shows on/off status of the appliance and on/off status of the heating elements.
- Cooking plate and base joint profile guarantee against soil infiltration.
- Surface temperature up to 350°C

Construction

- Unit constructed according to DIN 18860_2 with 20 mm drop nose top and 70 mm recessed plinth.
- Flat surface construction with minimal hidden areas to easily clean all surfaces
- Cooking surface is an electrically heated solid plate made from 20 mm thick stainless steel AISI 316 - DIN 1.4404.
- IPX5 water resistance certification.
- 2mm thick top in stainless steel AISI 304 - DIN 1.4301.
- Internal frame for heavy duty sturdiness in stainless steel.

Optional Accessories

- Connecting rail kit, 800mm PNC 912500
- Stainless steel side panel, 800x700mm, freestanding PNC 912509
- Portioning shelf, 500mm width PNC 912523
- Portioning shelf, 500mm width PNC 912553
- Folding shelf, 300x800mm PNC 912577
- Folding shelf, 400x800mm PNC 912578
- Fixed side shelf, 200x800mm PNC 912583
- Fixed side shelf, 300x800mm PNC 912584

APPROVAL: _____

• Fixed side shelf, 400x800mm	PNC 912585	<input type="checkbox"/>	• Stainless steel dividing panel, 800x700mm, (it should only be used between Electrolux Professional thermaline Modular 80 and thermaline C80)	PNC 913668	<input type="checkbox"/>
• Stainless steel front kicking strip, 500mm width	PNC 912631	<input type="checkbox"/>	• Stainless steel side panel, 800x700mm, flush-fitting (it should only be used against the wall, against a niche and in between Electrolux Professional thermaline and ProThermetic appliances and external appliances - provided that these have at least the same dimensions)	PNC 913684	<input type="checkbox"/>
• Stainless steel side kicking strip left and right, freestanding, 800mm width	PNC 912655	<input type="checkbox"/>			
• Stainless steel side kicking strip left and right, back-to-back, 1610mm width	PNC 912661	<input type="checkbox"/>			
• Stainless steel plinth, freestanding, 500mm width	PNC 912860	<input type="checkbox"/>			
• Connecting rail kit: modular 80 (on the left) to ProThermetic tilting (on the right), ProThermetic stationary (on the left) to ProThermetic (on the right)	PNC 912971	<input type="checkbox"/>			
• Connecting rail kit: modular 80 (on the right) to ProThermetic tilting (on the left), ProThermetic stationary (on the right) to ProThermetic (on the left)	PNC 912972	<input type="checkbox"/>			
• Endrail kit, flush-fitting, left	PNC 913109	<input type="checkbox"/>			
• Endrail kit, flush-fitting, right	PNC 913110	<input type="checkbox"/>			
• Scraper for smooth plates	PNC 913119	<input type="checkbox"/>			
• Endrail kit (12.5mm) for thermaline 80 units, left	PNC 913200	<input type="checkbox"/>			
• Endrail kit (12.5mm) for thermaline 80 units, right	PNC 913201	<input type="checkbox"/>			
• Stainless steel side panel, left, H=700	PNC 913214	<input type="checkbox"/>			
• Stainless steel side panel, right, H=700	PNC 913215	<input type="checkbox"/>			
• T-connection rail for back-to-back installations without backsplash (to be ordered as S-code)	PNC 913227	<input type="checkbox"/>			
• Insert profile D=800mm	PNC 913230	<input type="checkbox"/>			
• Perforated shelf for warming cabinets and cupboard bases (one-side operated TL80-85-90 and two-side operated for TL80)	PNC 913233	<input type="checkbox"/>			
• Energy optimizer kit 14A - factory fitted	PNC 913244	<input type="checkbox"/>			
• Endrail kit, (12.5mm), for back-to-back installation, left	PNC 913249	<input type="checkbox"/>			
• Endrail kit, (12.5mm), for back-to-back installation, right	PNC 913250	<input type="checkbox"/>			
• Endrail kit, flush-fitting, for back-to-back installation, left	PNC 913253	<input type="checkbox"/>			
• Endrail kit, flush-fitting, for back-to-back installation, right	PNC 913254	<input type="checkbox"/>			
• Side reinforced panel only in combination with side shelf, for freestanding units	PNC 913258	<input type="checkbox"/>			
• Side reinforced panel only in combination with side shelf, for back-to-back installations, left	PNC 913271	<input type="checkbox"/>			
• Side reinforced panel only in combination with side shelf, for back-to-back installation, right	PNC 913272	<input type="checkbox"/>			
• Shelf fixation for TL80-85-90 one-side operated, TL80 two-side operated	PNC 913279	<input type="checkbox"/>			
• Filter W=500mm	PNC 913664	<input type="checkbox"/>			

Recommended Detergents

- C41 HI-TEMP RAPID DEGREASER, 1 pack of six 1 lt. bottles (trigger incl.) PNC 0S2292

Front

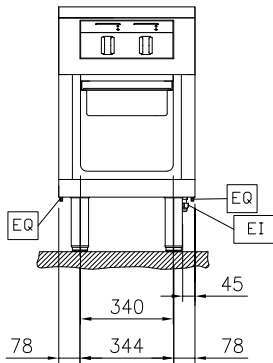

Side

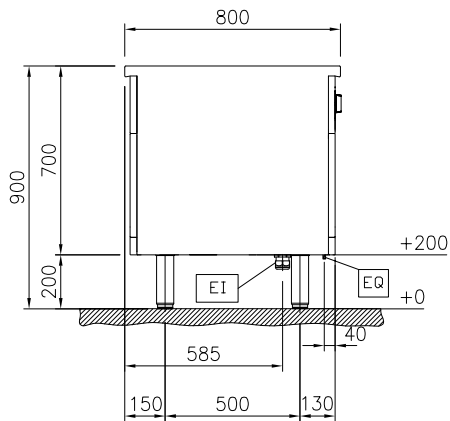

EI = Electrical inlet (power)
 EQ = Equipotential screw

Top

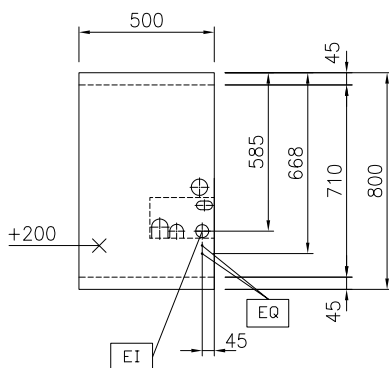
Electric

Supply voltage: 400 V/3N ph/50/60 Hz
 Total Watts: 6 kW

Key Information:

Working Temperature MIN: 80 °C
 Working Temperature MAX: 350 °C
 External dimensions, Width: 500 mm
 External dimensions, Depth: 800 mm
 External dimensions, Height: 700 mm
 Net weight: 100 kg
 Configuration: On Base; One-Side Operated

Sustainability

Current consumption: 13 Amps

Optional Accessories

- Connecting rail kit, 800mm PNC 912500
- Stainless steel side panel, 800x700mm, freestanding PNC 912509
- Portioning shelf, 500mm width PNC 912523
- Portioning shelf, 500mm width PNC 912553
- Folding shelf, 300x800mm PNC 912577
- Folding shelf, 400x800mm PNC 912578
- Fixed side shelf, 200x800mm PNC 912583
- Fixed side shelf, 300x800mm PNC 912584
- Fixed side shelf, 400x800mm PNC 912585
- Stainless steel front kicking strip, 500mm width PNC 912631
- Stainless steel side kicking strip left and right, freestanding, 800mm width PNC 912655
- Stainless steel side kicking strip left and right, back-to-back, 1610mm width PNC 912661
- Stainless steel plinth, freestanding, 500mm width PNC 912860
- Connecting rail kit: modular 80 (on the left) to ProThermetic tilting (on the right), ProThermetic stationary (on the left) to ProThermetic (on the right) PNC 912971
- Connecting rail kit: modular 80 (on the right) to ProThermetic tilting (on the left), ProThermetic stationary (on the right) to ProThermetic (on the left) PNC 912972
- Endrail kit, flush-fitting, left PNC 913109
- Endrail kit, flush-fitting, right PNC 913110
- Scraper for smooth plates PNC 913119
- Endrail kit (12.5mm) for thermaline 80 units, left PNC 913200
- Endrail kit (12.5mm) for thermaline 80 units, right PNC 913201
- Stainless steel side panel, left, H=700 PNC 913214
- Stainless steel side panel, right, H=700 PNC 913215
- T-connection rail for back-to-back installations without backsplash (to be ordered as S-code) PNC 913227
- Insert profile D=800mm PNC 913230
- Perforated shelf for warming cabinets and cupboard bases (one-side operated TL80-85-90 and two-side operated for TL80) PNC 913233
- Energy optimizer kit 14A - factory fitted PNC 913244
- Endrail kit, (12.5mm), for back-to-back installation, left PNC 913249
- Endrail kit, (12.5mm), for back-to-back installation, right PNC 913250
- Endrail kit, flush-fitting, for back-to-back installation, left PNC 913253
- Endrail kit, flush-fitting, for back-to-back installation, right PNC 913254
- Side reinforced panel only in combination with side shelf, for freestanding units PNC 913258

- Side reinforced panel only in combination with side shelf, for back-to-back installations, left PNC 913271
 - Side reinforced panel only in combination with side shelf, for back-to-back installation, right PNC 913272
 - Shelf fixation for TL80-85-90 one-side operated, TL80 two-side operated PNC 913279
 - Filter W=500mm PNC 913664
 - Stainless steel dividing panel, 800x700mm, (it should only be used between Electrolux Professional thermaline Modular 80 and thermaline C80) PNC 913668
 - Stainless steel side panel, 800x700mm, flush-fitting (it should only be used against the wall, against a niche and in between Electrolux Professional thermaline and ProThermetic appliances and external appliances - provided that these have at least the same dimensions) PNC 913684
- ### Recommended Detergents
- C41 HI-TEMP RAPID DEGREASER, 1 pack of six 1 lt. bottles (trigger incl.) PNC 0S2292